

Un-matched Hybrid Tees Series 390

Features

- Models from 1.14 GHz to 140GHz

The Flann Series 390 range of un-matched Hybrid Tees are waveguide sections accurately machined and assembled to form a conventional hybrid tee junction.

Precise machining yields the symmetrical construction necessary to ensure high isolation between the E and H plane ports and balanced power division in the “through” waveguide.

The H plane input provides in-phase outputs whilst the E plane input provides outputs of opposite phase.

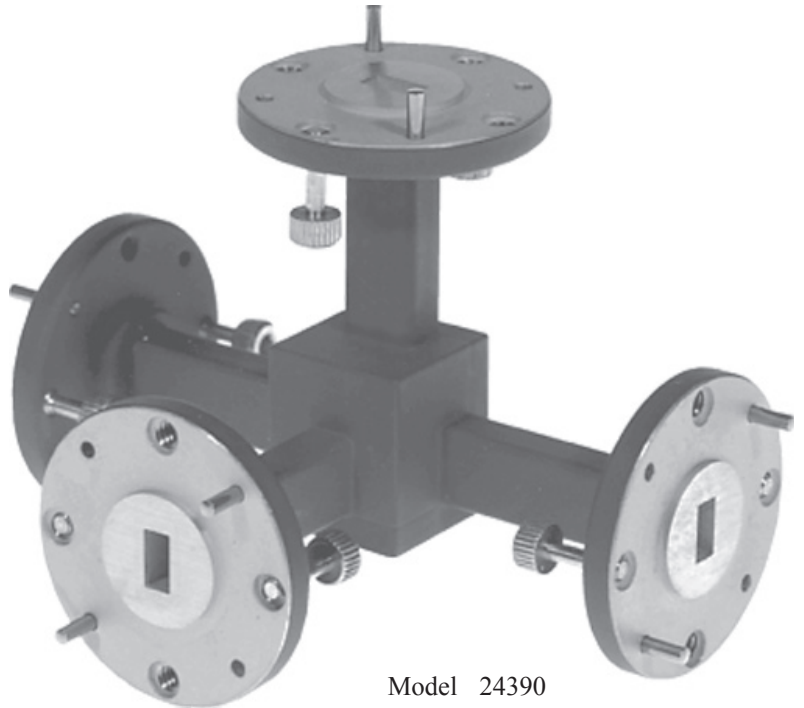

Model 24390

Un-matched hybrid tees are available in lower frequency bands; details on request.

Model	Frequency Range (GHz)	Waveguide			Dimensions (mm)	
		WG	R	WR	A	B
20390	17.6 - 26.7	20	220	42	70	35
22390	26.4 - 40.1	22	320	28	70	35
23390	33.0 - 50.1	23	400	22	70	35
24390	39.3 - 59.7	24	500	19	70	35
25390	49.9 - 75.8	25	620	15	48	24
26390	60.5 - 92.0	26	740	12	48	24
27390	73.8 - 112	27	900	10	48	24
28390	92.3 - 140	28	1200	8	48	24

ORDERING INFORMATION

Model: Description

Example: Model 22390 Hybrid Tee, Un-matched

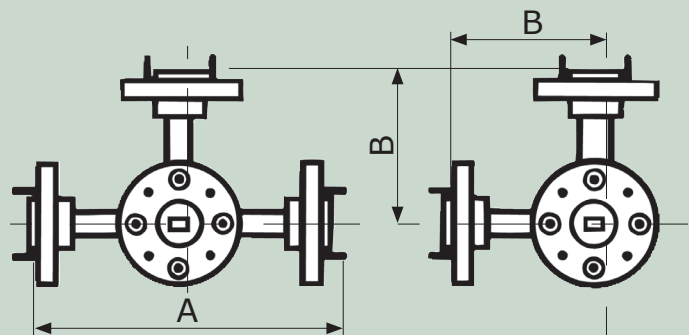

Series 390

For standard flange types and recommendations see pages 118 onwards