



FLANN MICROWAVE

Waveguide Switch, Compact H-plane

Series 337

Features

- Compact lightweight waveguide switch
- Increased data capacity
- Ultra-high RF & Mechanical performance
- High power (peak & CW)
- 24 – 500 GHz models available
- Capability to integrate with other instruments in same topology as single-piece unit
- Extended Frequency Range
- 20 – 50ms switching time



Model 29337-2E-11T13
with Miniature FSM-45 Flange
Interface

Flann Microwave offers a comprehensive range of waveguide switches with high performance.

As such, we are proud to launch a new range of millimetric waveguide switches to suit the increasing demand for the next stage of 5G, 6G & LEO/GEO/MEO satellites and expanding use by Military & Astronomy between 28-500 GHz.

The new 337 series is a range of DC voltage driven, compact, low mass, low inertia, low insertion loss, high RF power switcher with high isolation and minimal PIM.

H-plane port orientation allows easy integration with other components, giving the potential to create an entire switching network to include multiple switches, combiners, or filters/diplexers etc.

The 337 series incorporates a number of unique design features to prevent wear and debris - (FOD) and to achieve a long, reliable life in harsh environments.

Rotor & stator are manufactured as single pieces with no contact or joining mechanisms, just two metal components with a sophisticated choked air gap.

The result is a very compact, very robust, perfect waveguide structure. A choice of drive control types and position tell-back options are available.

Manual operation 337 Series switches are available. These can be requested by replacing [-2E] or [-3E] with [-2] or [-3].

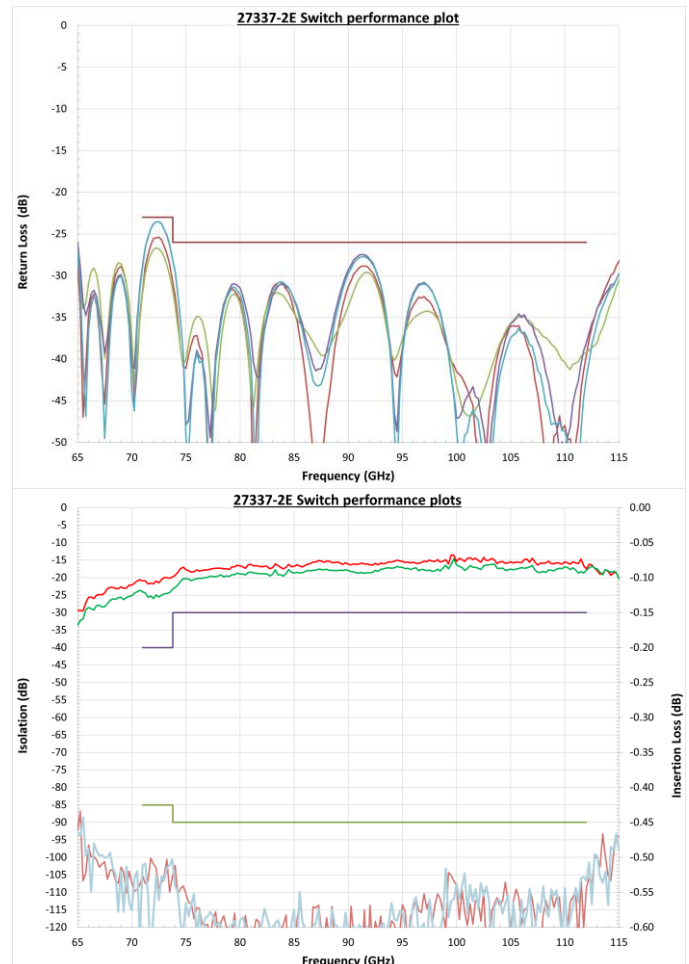

FLANN MICROWAVE LTD.

Dunmere Road
Bodmin
Cornwall
PL31 2QL

GET IN TOUCH

Tel: +44 (0)1208 77777
sales@flann.com
www.flann.com



Model	WG	WR	Performance figures for use with FM-45 flange interface				Mean Power (W)	Flange to Flange Dimension (mm)	
			Frequency (GHz)*	Min Return Loss (dB)	Max Insertion Loss (dB)	Min Isolation (dB)		FSM-45	UBR/UG/1785-2a
21337	21	34	21.7-33.0						
22337	22	28	26.4-40.1	26.0	0.08	90	700	N/A	38.0
23337	23	22	33.0-50.1	26.0	0.10	90	400	N/A	33.0
24337	24	19	39.3-60.0	25.5	0.10	90	350	N/A	30.0
25337	25	15	49.9-75.8	25.5	0.11	90	250	22.5	32.1
26337	26	12	60.0-92.0	25.0	0.12	90	200	18.0	27.6
27337	27	10	73.8-112	25.5	0.16	90	150	18.0	27.6
28337	28	8	90.0-140	24.5	0.20	85	100	15.5	25.1
29337	29	6	110-173	21.0	0.25	85	80	15.5	25.1
30337	30	5	140-220	21.5	0.40	80	55	15.5	25.1
31337	31	4	170-261	19.5	0.50	70	45	15.5	25.1
32337	32	3	217-330	17.0	1.00	60	30	15.5	25.1

*Extended frequency ranges available.

Related Products

Series 330 – Waveguide Switch, Space Flight H-plane 2-way
Series 333 - Waveguide Switch E-plane 2 and 3 way
Series 334 - Waveguide Switch, DC Driven E-plane 2 and 3 way
Series 338 - Waveguide Switch, Power over Ethernet E-plane 2 and 3 way

Custom Design

Custom built instruments can be supplied; please contact the sales team for more information sales@flann.com

Notes

WG22 to WG27 can use industry standard or miniature flanges; however, they are offered with an optional set of very short flange adaptors to convert to industry standard flange types.
The switch has H-plane ports as standard however they can be fitted with very short-stepped twists to convert to E-plane & standard flanges.

Options

- Drop-in availability
- Integration with other components
- Multiple or ganged versions
- TVAC suitable option

Environmental Specifications

Operating temperature: -40°C to + 85°C
Non-Operating temperature: -45°C to + 115°C

FLANN MICROWAVE LTD.

Dunmere Road
Bodmin
Cornwall
PL31 2QL

GET IN TOUCH

Tel: +44 (0)1208 77777
sales@flann.com
www.flann.com



Ordering Information

Be advised that not all options are compatible with each other. Contact Flann for specific requirements.

WG	Series	Channels	Flange Type	Voltage	Drive Type	Redundancy	Connector type
21 - 32	337	-2E -3E	1 2 3 4	1 2	T = TTL D = Direct	1=No 1 Pair (Tell-back) 2=Yes 2 Pair (Tell-back)	1 2 3

Example: 29337-2E-11T11

Flange Type

WG	Option Code			
	1	2	3	4
21			UG-1530/U	UBR260
22			UG-599/U	UBR320
23			UG-383/U-AC	
24		1785-2a	UG-383/U-M-AC	
25	FSM-45	1785-2a	UG-385/U-AC	
26	FSM-45	1785-2a	UG-387/U-AC	
27	FSM-45	1785-2a	UG-387/U-M-AC	
28	FSM-45	1785-2a	UG-387/U-M-AC	
29	FSM-45	1785-2a	UG-387/U-M-AC	
30	FSM-45	1785-2a		
31	FSM-45	1785-2a		
32	FSM-45	1785-2a		

Voltage (VCC)

Option code	Voltage (V)
1	+22 to +32 dc
2	+10 to +14 dc

Redundancy

Option Code	Redundancy
1	No (1 Pair Tell-back)
2	Yes (2 Pair Tell-back) *

* Not available with 9-way Micro-D connector (Connector Type Option Code 1)

Connector types

Option Code	Connector Type
1	9-way Micro-D
2	15-way Micro-D
3	Trailing Lead

FLANN MICROWAVE LTD.

Dunmere Road
Bodmin
Cornwall
PL31 2QL

GET IN TOUCH

Tel: +44 (0)1208 77777
sales@flann.com
www.flann.com



Introduction

We offer the switch with two configurations.

1. Direct External Control
2. TTL control.

The next paragraphs detail these options.

The switch is mechanically and magnetically identical in both cases. In the former the internal control circuitry is not built into the switch.

The default connection type for both switch configurations is a male 9-way micro-d connector, the pin out of this connector matches the image below.

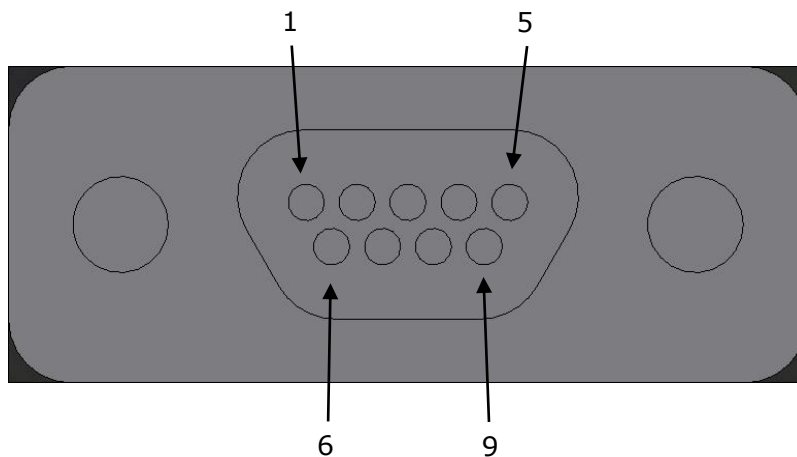

Direct External Control (Controlling the Coils Directly).

When the switch is used in this configuration the circuitry for controlling the movement of the switch is external to the switch. The pins required pins for this style of switch are:

Pin	Pin Function	Voltage Level
1	A Coil 1	VCC
2	GND	0V
3	TTL Output 1	TTL High or Low
4	TTL Supply	+5V
5	A Coil 2	VCC
6	B Coli 1	VCC
7	TTL Output 2	TTL High or Low
8	GND	0V
9	B Coil 2	VCC

FLANN MICROWAVE LTD.

Dunmere Road
Bodmin
Cornwall
PL31 2QL

GET IN TOUCH

Tel: +44 (0)1208 77777
sales@flann.com
www.flann.com



To drive the switch a (30ms recommended) VCC pulse needs to be applied to the coil inputs, when switching between two positions the B Coils coil should be driven in the same direction each time and the A coil drive should be energised so the current flows in the opposite sense.

A Coil Energised	B Coil Energised	Resulting Switch Position
+ve	+ve	Position 1
-ve	+ve	Position 2

Example External Drive Circuits

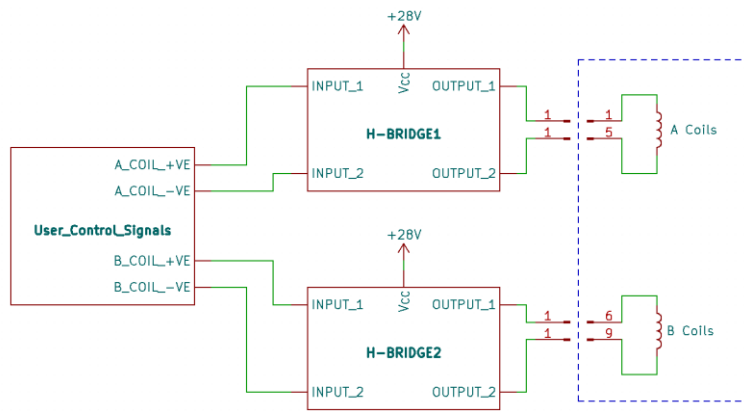

Figure 1: Two H-Bridge Drive

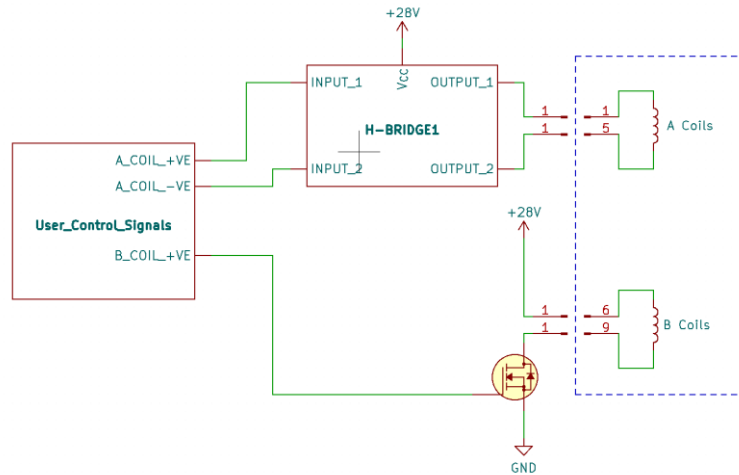

Figure 2: One H-Bridge and one switch device Drive

**Position Indication**

The two pins labelled TTL Output 1 & 2 give a positive indication of the rotational position of the switch. The following truth table shows the sense of these indications.

Switch Position	Port 1 Connected to	Port 3 Connected to	TTL Output 1	TTL Output 2
1	Port 2	Port 4	0	1
2	Port 4	Port 2	1	0

The maximum voltage that should be applied to the TTL Supply line is +5V, the TTL outputs will return a voltage at the same level as the TTL Supply when returning a high.

TTL Input Control

For this configuration the control of the switch position is placed within the switch itself. Control of the switch is achieved by the use of a two channel TTL input (30ms recommended pulse length), with each channel corresponding to a switch position such that it matches the truth table below:

TTL Channel 1	TTL Channel 2	Switch Position
0	0	No change
1	0	Move to (or stay at) Position 1
0	1	Move to (or stay at) Position 2
1	1	No change

This configuration requires a VCC input supply, +5V TTL supply. The required pins for this configuration are:

Pin	Pin Function	Voltage Level
1	TTL Supply	+5V
2	TTL Input 2	TTL High or Low; Max Input 5V
3	TTL Output 1	TTL High or Low
4	GND	0V
5	Coil Supply	VCC
6	TTL Input 1	TTL High or Low; Max Input 5V
7	GND	0V
8	TTL Output 2	TTL High or Low
9	GND	0V

The maximum voltage that should be applied to the TTL Supply line and TTL Input is +5V, the TTL outputs will return a voltage at the same level as the TTL Supply when returning a high.



FLANN MICROWAVE

Waveguide Switch, Compact H-plane

Series 337

Position Indication

The two pins labelled TTL Output 1 & 2 give a positive indication of the rotational position of the switch. The following truth table shows the sense of these indications.

Switch Position	Port 1 Connected to	Port 3 Connected to	TTL Output 1	TTL Output 2
1	Port 2	Port 4	0	1
2	Port 4	Port 2	1	0

FLANN MICROWAVE LTD.

Dunmere Road
Bodmin
Cornwall
PL31 2QL

GET IN TOUCH

Tel: +44 (0)1208 77777
sales@flann.com
www.flann.com